

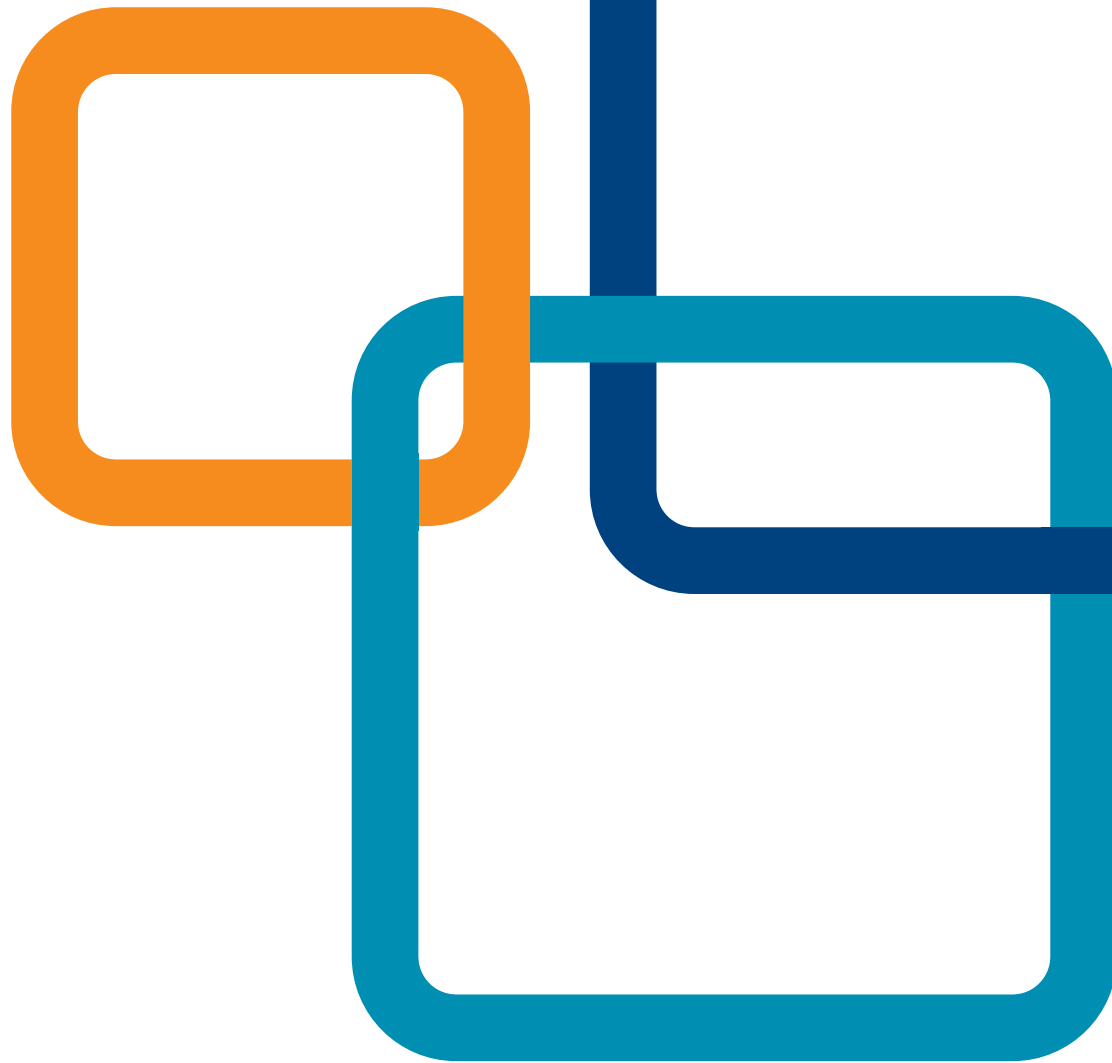

Workspace
Technology Limited



Technology Paper 006

Power Usage Effectiveness (PUE) - An Overview & Practical Measurement

Workspace Technology Limited

Technology House, 8 Emmanuel Court, Reddicroft Sutton Coldfield, West Midlands B73 6AZ

Telephone: 0121 354 4894 Facsimile: 0121 354 6447

www.workspace-technology.com email: sales@workspace-technology.com

Published in May 2010

Introduction

Power Usage Effectiveness (PUE) and its reciprocal Data Centre Infrastructure Efficiency (DCiE) metrics were introduced in 2007 by the Green Grid as a method of determining the relative efficiency of a server room or data centre facility.

PUE is a figure which is now recognised and reported at board level within many organisations. This Technology Paper provides an overview of PUE and its importance in the drive towards energy efficiency and details how to deliver practical measurement within a data centre facility.

Efficiency Measurement & Metrics

As part of any energy reduction strategy it is imperative to recognise the importance of establishing metrics to specifically measure data centre efficiency. Metrics can show how systems are currently performing and help drive the “tune up” process.

There are two related metrics that are used in the industry:

Power Usage Effectiveness (PUE) and Data Centre Infrastructure Efficiency (DCiE).

The PUE is defined as follows:

Power Usage Effectiveness (PUE) =

$$\frac{\text{Total Facility Power}}{\text{I.T Equipment Power}}$$

and its reciprocal, the DCiE is defined as:

Data Centre Infrastructure Efficiency (DCiE) =

$$\frac{\text{I.T Equipment Power}}{\text{Total Facility Power}}$$

I.T Equipment Power – This includes the load associated with all of the I.T equipment, such as computer, storage, and network equipment, along with supplemental equipment such as KVM switches, monitors, and workstations/laptops used to monitor or control the Data Centre.

Total Facility Power – This includes everything that supports the I.T equipment load such as:-

- Total I.T Equipment Power
- Power delivery components such as UPS, switch gear, generators, PDU's, batteries, and distribution losses external to I.T equipment.
- Cooling system components such as chillers, computer room air conditioning units, direct expansion air handler (DX) units, pumps, and cooling towers.
- Other misc. loads including lighting, BMS panels etc.

Note - Data Centre Infrastructure Efficiency or DCiE was originally known as just Data Centre Efficiency or DCE. The Green Grid, which advocates the use of both PUE and DCiE, added the word infrastructure to clear up what was considered misunderstandings over the term Data Centre Efficiency. The metric itself did not change.

Although PUE is more commonly used today, some people prefer DCiE because Data Centres with greater electrical efficiency achieve a higher score, where the PUE metric shows a lower score the more energy efficiency the facility achieves.

Green Grid Overview

The Green Grid is a global consortium of companies focused on Data Centre energy efficiency. Launched in 2007, the group's members include a broad range of Data Centre hardware and software manufacturers.

The groups stated goals are:-

- Defining meaningful, user-centric models and metrics
- Developing standards, measurement methods, processes, and new technologies to improve performance against the defined metrics
- Promoting the adaption of energy-efficient standards processes, measurements and technologies.

Why Does PUE Matter?

The carbon footprint of a data centre is the amount of carbon dioxide produced as part of the ongoing operation of the facility. Carbon dioxide is widely recognised as a greenhouse gas that contributes to the trapping of heat from the sun and therefore warms the Earth. Many scientists and environmentalists today are concerned that human activity is causing such problems, prompting them and various agencies worldwide to call for the reduction in carbon emissions.

PUE was developed as a simple metric to demonstrate how efficiently the data centre supporting infrastructure is operating relative to the critical load.

The table below clearly demonstrates the operational savings that can be made when the PUE/DCiE performance of a Data Centre facility is maximised.

Example PUE / DCiE Energy Performance Table

Critical Load Kw	DCiE 25% PUE 4.0	DCiE 50% PUE 2.0	DCiE 66% PUE 1.5	DCiE 80% PUE 1.25	DCiE 100% PUE 1.0
10	£35,040	£17,520	£13,140	£10,950	£8,760
20	£70,080	£35,040	£26,280	£21,900	£17,520
25	£87,600	£43,800	£32,850	£27,375	£21,900
50	£175,200	£87,600	£65,700	£54,750	£43,800
100	£350,400	£175,200	£131,400	£109,500	£87,600
150	£525,600	£262,800	£197,100	£164,250	£131,400
200	£700,800	£350,400	£262,800	£219,000	£175,200
300	£1,051,200	£525,600	£394,200	£328,500	£262,800
500	£1,752,000	£876,000	£657,000	£547,500	£438,000
750	£2,628,000	£1,314,000	£985,500	£821,250	£657,000
1000	£3,504,000	£1,752,000	£1,314,000	£1,095,000	£876,000

Rate £ per Kwh 0.1

As an example, for every 0.1 improvement on the PUE ratings with a 1MW critical load, an energy saving in the region of £87,000 per year can be achieved.

The savings in energy are directly related to the reduction in carbon emissions.

It is therefore necessary to measure your data centres capacity and resource consumption to understand how green it is and the impact of any upgrades that you make. It should be understood that PUE does not itself show how efficient the critical load is operating. The Green Grid is developing a suite of measurements that show computer efficiency.

Alternative Metrics

Technology Carbon Efficiency (TCE)

Whilst not a commonly known term this metric provides a “true” indication of the relative global carbon efficiency of a data centre or server room facility. Technology Carbon Efficiency (TCE) was introduced in 2007 by CS Technology.

Generating regions typically have a variable mix of coal fired, nuclear, gas and renewable power generation such a hydro electric and wind turbines. Each generation method has an associated carbon emission level based on the overall lifecycle of the power plant. Those regions that have a greater reliance on nuclear or renewable sources will benefit from a lower carbon dioxide level per Mw/h of electricity produced.

The TCE metric takes into account the energy source used to produce the electricity and the exact electrical mix that comes from the local country or region. This metric simply multiplies the PUE reading with the Electricity Carbon Emission Rate of the region.

TCE is defined as follows:

$$\text{Total Carbon Efficiency (TCE)} = \text{PUE} \times \text{Electricity Carbon Emission Rate}$$

The lower the TCE figure the more energy efficient the data centre is. TCE enables companies to compare different facilities in different regions of the world.

Carbon Dioxide Emissions from Electricity and Heat Generation, by Country.

Critical Load Kw	DCiE 25% PUE 4.0	DCiE 50% PUE 2.0
Brazil	178.	81
Canada	405	184
China	1737	788
Denmark	751	341
France	187	85
Germany	890	404
Iceland	2.2	1
India	2081	944
Italy	890	404
Japan	921	418
Korea	1022	464
Russia	725	329
Singapore	1181	536
Spain	771	350
Sweden	105	48
Turkey	965	438
UK	1113	505
United States	1232	559
World	1113	505

Example TCE Calculations

Data Centre Location	PUE	TCE
UK	1.5	$1.5 \times 505 = 757.5$
Sweden	4.0	$4.0 \times 48 = 192.00$

As can be seen from the example above, whilst the PUE figures of the UK data centre are very good, compared to the Swedish data centre the TCE figure is much higher. This means that its relative carbon emissions per Kw/hr of electricity are higher.

Computer Power Efficiency (CPE)

Another approach to evaluating a Data Centre's performance is to calculate its electrical overhead and then factor in the average CPU utilization of the servers it houses. Known as Computer Power Efficiency (CPE) this metric was first introduced by the Green Grid in 2007.

$$\text{Computer Power Efficiency (CPE)} = \frac{\text{I.T Equipment Utilization}}{\% \text{ PUE}}$$

This figure is used to help focus I.T professionals to maximise the use of processing capability. The higher the figure, the greater the quantity of useful work that is being completed per Kw of electricity.

Example CPE Calculations

I.T Equipment Utilization	PUE	CPE
10%	1.5	$10/1.5 = 6.6\%$
50%	4.0	$50/4.0 = 12.5\%$

As can be demonstrated from the above figures, if the server / I.T technology is under utilised then this will impact on the overall efficiency, thereby reducing the useful work being performed. Techniques which include server and application virtualisation, shared storage (SAN's), consolidation, standardisation and processor hibernation ensure that computer utilisation is improved, which will have a positive effect on the data centre CPE results.

Power Usage Effectiveness Measurement Guidelines

Very often PUE figures are estimations based on equipment operating ratings. Whilst these figures are useful for design and predictive purposes they are not recognised as results under the Green Grid guidelines. The only true method of calculating the PUE of a facility is by taking direct electrical measurements.

PUE Reporting

The Green Grid has published a set of guidelines for the reporting of PUE/DCiE figures to ensure standardization which helps underline the credibility of these figures. These guidelines provide measurement sophistication levels, and details the format of presentation.

Class	Description	Benefit to Reporting Organization
Unrecognised	A reported result only	None
Reported	A reported result with a claim this is based in the Green Grid Guidelines	Enables organization to explain methodology of results
Registered	A reported result based on guidelines provided to the Green Grid data performance database	Official Registration of Result. Link to Report via the Green Grids Web Site
Certified	A reported result with key additional data required for third party validation or certification of results, provided to the Green Grid	As registered plus consideration for Green Grid award recognition programs

Levels of Measurement

PUE/DCiE figures are dynamic and will vary as loads modulate up and down during the course of a day, week, month and year.

The Green Grid has categorised 3 levels based on frequency and granularity of measurement. These provide flexibility for the differing levels and capabilities within individual data centres.

Description	Level 1 (L1) Basic	Level 2 (L2) Intermediate	Level 3 (L3) Advanced
Measurement Interval	At least monthly basis	At least on a daily basis	On a continuous basis
I.T Equipment Measurement Point	Normally the UPS output	Ideally from perimeter PDU's	From individual I.T equipment
Totally Facility Power	Main distribution panel feeding all mechanical and UPS inputs	Multiple Readings from main distribution points	From individual pieces of data centre equipment

Increased granularity in measurement enables better analysis of PUE results. Ideally multiple measurements are taken on a constant basis through the deployment of distributed energy meters and intelligent PDU's.

1.6 PUE/L1/MW	Monthly Average PUE of 1.6 using weekly readings with Level 1 meter placements
1.8 PUE/L2/WD	Weekly Average PUE of 1.8 using Daily readings with Level 2 Intermediate meter placements
2.1 PUE/L3/YC	Yearly average PUE of 2.1 using a constant measurement with Level 3 advanced meter placements.

PUE Reporting Examples

Common Issues When Reporting PUE / DCiE

There are a number of common issues which can lead to error or the misinterpretation of results. One of the key problems is the correct designation and allocation of measured load i.e. Critical I.T, Facility or General Building. It is important where there are shared facilities that appropriate deductions can be made to ensure that equipment which is not part of the data centre is excluded from the calculation. Misallocation of readings will deliver inaccurate PUE figures.

PUE / DCiE figures give an indication of the relationship of total facility power relative to the critical load. As was demonstrated with the TCE and CPE example (calculations detailed earlier in this paper), on their own PUE / DCiE do not show how efficiently the data centre is performing.

The PUE / DCiE are dynamic readings and will vary with fluctuation to the critical I.T load. Changes to the critical load could indeed have a negative impact on the PUE readings. For example where a group of servers are virtualised these may reduce the critical load but when the supporting infrastructure e.g. cooling load remains unchanged the PUE figure will increase. This is one reason to ensure that a comprehensive range of readings can be obtained. Greater levels of information help deliver informed analysis of the results which in turn enables I.T and Data Centre professionals to determine how best to balance and tune the infrastructure to maximise performance.

Standard Format for Communicating PUE/DCiE Measurements

PUE/DCiE should be reported in the following way PUE/xx/y/z

xx = Level of Measurement designated L1, L2 or L3.

y = Averaging period of data collection designated Y = Yearly, M = Monthly, W = Weekly, D = Daily.

z = Frequency of measurement designated Y = Yearly, M = Monthly, W = Weekly, D = Daily, C = Constant

Note: It is recommended that Level 1 and Level 2 measurements are taken at approximately the same time of day to ensure it captures a similar profile of events.

Power Vs Energy

As explained above there are three recognised levels of PUE/DCiE measurement. Level 1 / 2 are based on instant Kilowatt readings. Level 3 / Advanced is based on a continuous or Kilowatt/Hour readings which reflects true total energy consumption of both critical and total facility equipment. A Level 3 reading can take place over an hourly, daily, weekly, monthly or annual basis. These figures will provide more accurate results and can be used to provide comparison of daily or seasonal cycles. As an example, they can show how free cooling technology helps improve PUE performance at night or during winter periods.

It is recommended that a full range of graphs are produced to enable accurate analysis of the performance variance of the PUE metric.

Negative PUE Readings

Theoretically if energy is offset through heat exchange technology or through onsite power generation, PUE readings can be less than 1.0. Currently, negative PUE or DCiE figures greater than 100% are not recognised as they are outside the scope of improving the internal architecture of the data centre. These should be taken into account when a measurement design and graph schedule is produced.

Practical PUE/DCiE Measurement

For many organisations it is possible to obtain PUE figures through the simple analysis of UPS output readings and total facility meter readings under the basic and intermediate L1 / L2 classifications.

It is however strongly recommended that organisations should consider the implementation of the Green Grids Level 3, Advanced measurement methodology. “EcoMeasure” a data centre energy measurement service from Workspace Technology is an example of the type of installations that will deliver Green Grid compliant PUE measurements.

EcoMeasure Integration Services

The deployment of EcoMeasure consists of sequenced activities to ensure that full and accurate Level 3 measurement can be achieved for each server room or data centre environment.

Step 1 - Electrical Services Audit

The initial step will require a site audit to establish measurement points to ensure “Total Facility Power” and “I.T Equipment Power” are measured accurately. The more points of measurement, the more accurate the information and the more analysis can be made for energy improvements. This service should also allow for any deductions for power not attributed to the data centre.

“Total Facility Power” is measured at the input power feeds to the data centre. This should represent the total power entering the data centre (for which the utility supplier will charge). Ideally this measurement will not only include the main input power but also key sub services i.e. mechanical plant and general data centre services.

The practical measurement point for “I.T Equipment Power” is the output of the UPS, UPS bypass switch, or critical distribution power boards which support the critical I.T equipment load.

Step 2 - EcoMeasure Design

Following the initial EcoMeasure audit, Workspace Technology engineers will generate a practical configuration which will include accurate measurement of “Total Facility Power” and “I.T Equipment Power”.

The output of this step is a high level electrical schematic with identified measurement points, PowerLogic equipment schedule, wiring configuration and software configuration parameters.

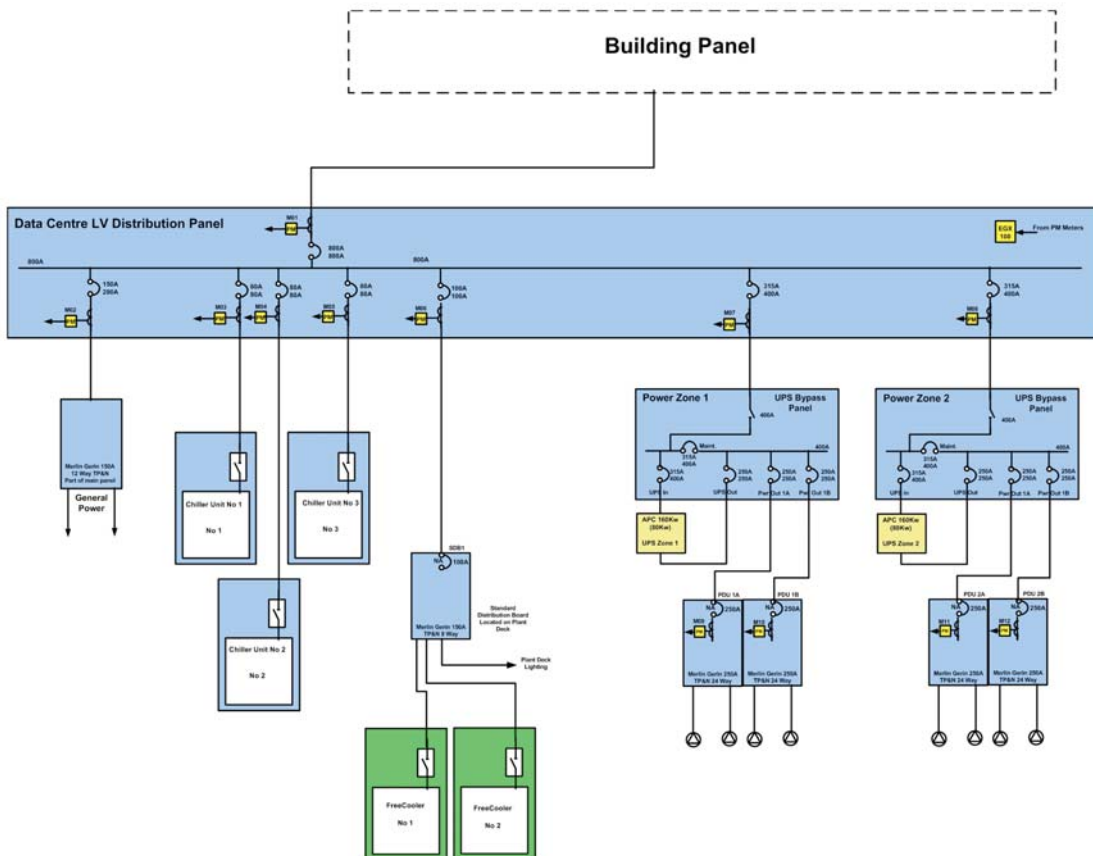

Example EcoMeasure Electrical Drawing

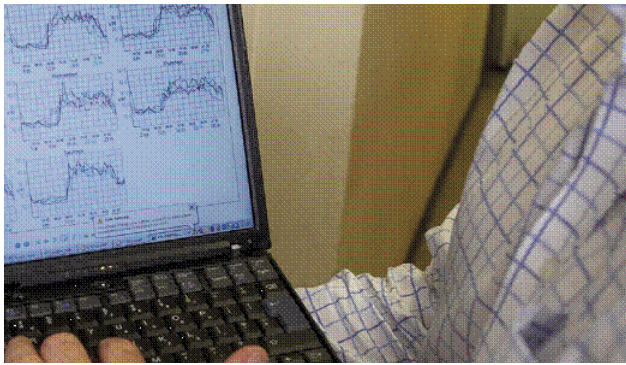

Step 3 - EcoMeasure Installation

Measurement technology will be deployed within power distribution boards as specified during the audit phase. Works will be programmed to ensure minimum disruption to services with 'out of hours' installations where power downs are required.

Installation services include all metres, control cable, gateway connections, PoE and Ethernet connectivity.

The result of this step is a fully installed and wired measurement and analysis solution.

Step 4 Configure and Commission "EcoMeasure Software"

Workspace Technology consultants will provide comprehensive configuration and set up of the PowerLogic* ION Enterprise software. A complementary range of graphs will be created to maximise energy performance analysis.

Meter Summary	Metre Type	I.D
Incoming Mains / Total Facility	PM750	M01
Standard Power Board PDU S	PM750	M02
Chiller Unit No 1	PM750	M03
Chiller Unit No 2	PM750	M04
Chiller Unit No 3	PM750	M05
Plant Top Standard Distribution Board	PM750	M06
UPS Bypass Power Zone 1	PM750	M07
UPS Bypass Power Zone 2	PM750	M08
Critical Power PDU1A	PM750	M09
Critical Power PDU1B	PM750	M10
Critical Power PDU2A	PM750	M11
Critical Power PDU2B	PM750	M12

Example EcoMeasure Measurement Schedule.

Graph Description	Reading	C	D	W	Y	Alarm
Total Room / Facility						
Total Room Amps	M01	Y	Y	Y	Y	N/A
Total Room Volts	M01	Y	Y	Y	Y	N/A
Total Room Watts	M01	Y	Y	Y	Y	N/A
Total Room Energy	M01	Y	Y	Y	Y	N/A
Total Room Energy Cost	M01	N/A	Y	Y	Y	N/A
Voltage Distortion	M01	Y	Y	Y	Y	+/-5%
Standard Services PDU S						
As per readings above	M02	Y	Y	Y	Y	Y
Chiller Unit No1						
As per readings above	M03	Y	Y	Y	Y	Y
Chiller Unit No2						
As per readings above	M04	Y	Y	Y	Y	Y
Chiller Unit No3						
As per readings above	M05	Y	Y	Y	Y	Y
Plant Deck Power / Dry Coolers						
As per readings above	M06	Y	Y	Y	Y	Y
Critical Load Power Zone 1 PDU 1A						
As per readings above	M09	Y	Y	Y	Y	Y
Critical Load Power Zone 1 PDU 1B						
As per readings above	M10	Y	Y	Y	Y	Y
Critical Load Power Zone 2 PDU 2A						
As per readings above	M11	Y	Y	Y	Y	Y
Critical Load Power Zone 2 PDU 2B						
As per readings above	M12	Y	Y	Y	Y	Y
Total Critical Load						
As per readings above	M09+M10+M11+M12	Y	Y	Y	Y	Y
Total Cooling Power						
As per readings above	M03+M04+M05+M06	Y	Y	Y	Y	Y
UPS No 1						
As per readings above	M07	Y	Y	Y	Y	Y
UPS No 2						
As per readings above	M08	Y	Y	Y	Y	Y
UPS No 1 Efficiency						
UPS Energy Efficiency Rating Shown as Percentage.	(M09+M10)/M07x100	Y	Y	Y	Y	Y
UPS No 2 Efficiency						
UPS Energy Efficiency Rating Shown as Percentage.	(M11+M12)/M08x100	Y	Y	Y	Y	Y

Example EcoMeasure Measurement Schedule.

Graph Description	Reading	C	D	W	Y	Alarm
Data Centre Infrastructure Efficiency (DCiE)						
Energy Efficiency Measurement Graphs Data Centre Infrastructure Efficiency "DCiE" presented as a percentage	$((M09+M10+M11+M12)/M01)*100$	Y	Y	Y	Y	Y
Power Usage Effectiveness (PUE)						
Energy Efficiency Measurement Graphs Power Usage Effectiveness Presented as figure	$M01/(M09+M10+M11+M12)$	Y	Y	Y	Y	Y
Technology Carbon Efficiency						
Relative Energy Efficiency Measurement Graphs = Power Usage Effectiveness x Electricity CO ² Carbon Emission Rate (UK = 0.53 per Kg/hr) Presented as CO ² Kg per kWh	$(M01/(M09+M10+M11+M12)) * 0.53$	Y	Y	Y	Y	Y
CO ² Emissions						
Total CO ² Emissions = Total Facility Power x UK Carbon Emission Rate (0.00053) Presented as CO ² Tonnes	$M01*0.00053$	Y	Y	Y	Y	Y
CO ² Savings (Relative to PUE = 2.0)						
Total CO ² Emissions Savings Relative to a Standard PUE Rating of 2.0 = 2-PUE x 0.00053 - Presented as CO ² Tonnes	$(2-(M01/(M09+M10+M11+M12)))*0.00053$	Y	Y	Y	Y	Y

Example EcoMeasure Measurement Schedule continued.

EcoMeasure Technology Platform

The **EcoMeasure** solution is delivered through the deployment of Schneider Electric, the industry leader in power metering and power management software products.

PowerLogic® ION Enterprise®* software is a complete power management solution which comprehensively delivers the management functions of the EcoMeasure service. It is a scalable software platform with options to support different numbers of remote devices and clients. The PowerLogic SW is also fully integrated into APC's InfrastruXure Central data centre management platform.

PowerLogic® PM750* meter The PM750 digital meters, provide flexible metering deployment within custom panels, switchboards, switchgear, gensets, motor control centres and UPS systems as required to deploy a complete EcoMeasure client solution.



PowerLogic® EGX100* Ethernet Gateway

The EGX100 gateway serves as an Ethernet coupler for PowerLogic System devices and for other communicating devices that use RS485 Modbus protocol. The EGX100 gateway offers complete access to all measurements and status information from connected devices.

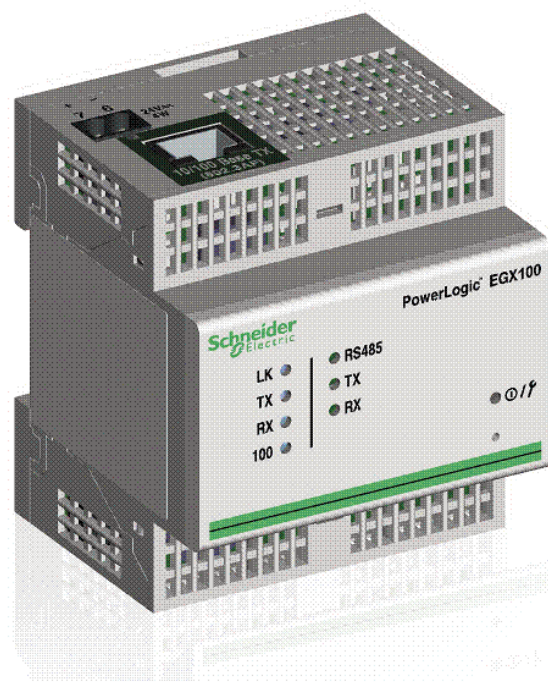

Conclusions

Conclusion

Power Usage Effectiveness (PUE) is an established and globally recognised metric for gauging the “infrastructure” efficiency and performance of a data centre.

Data Centre Managers and I.T professionals are encouraged to maximise the efficiency of their facility. They should aim to deliver maximum performance in three key areas;

- 1 Data Centre Infrastructure (measured through PUE)
- 2 Maximise useful work per Watt of electricity (measured through CPE)
- 3 Endeavour to use the most energy efficient power source (Energy Carbon Ratings)

By combining these strategies successfully the overall performance and energy savings can be considerable, not only helping reduce data centre operational costs but also delivering a meaningful contribution to a companies commitment to reduction in CO² emissions.

With the introduction of carbon related tax's in many regions it is now imperative that I.T and Data Centre Managers implement strategies for accurate measurement and analysis of PUE.

This can be achieved through the implementation of technology and services such as Workspace Technology's EcoMeasure solution.

About Workspace Technology

Workspace Technology's Data Centre Solutions division provide expert data centre, communications and server room solutions and services for public sector and corporate clients across the UK.

Workspace Technology is proud to be an approved “Endorser” for the European Commissions “Code of Conduct for Data Centre Efficiency” Workspace Technology is committed to help clients reduce their carbon footprint through the deployment of “Best Practice” energy efficient technology and design, for new and existing data centre environments.

Further details of Workspace Technology's products and services can be found at www.workspace-technology.com.



Approved “Endorser” EU “Code of Conduct on Data Centre Efficiency”



APC Elite Partner
Data Centre Certified



Workspace Technology's “Commitment to help clients reduce their carbon footprint through the deployment of energy efficient technology and design”.



Workspace
Technology Limited

Technology House, 5 Emmanuel Court,
Reddicroft Sutton Coldfield,
West Midlands B72 1TJ

Tel : 0121 354 4894

Fax: 0121 354 6447

email : sales@workspace-technology.com

www.workspace-technology.com